

User Manual



Please read the manual before installation and operation.

Drawell International Technology Limited

Chongqing Drawell Instrument CO.,Ltd

Add: Suite 2705, Building No.12, Shiyou Road No.1, Yuzhong District, Chongqing, China
Tel: 0086-023-63268643

Shanghai Drawell Scientific Instrument Co.,Ltd

Add : Suite 1117, Lane561 XiuChuan Rd., PuDong New Area, Shanghai, China

Web : www.drawell.com.cn

Email : sales05@drawell.com.cn

DENSITY BALANCE

INSTRUCTION

CATALOG

First: Model Specification And Index.....	01
Second: Working Condition	01
Third: Operation Requirements.....	01
Fourth: Halogen Problem.....	01
Fifth: Installation Diagram.....	03
Sixth: Panel And Icon.....	04
Seventh: Density Testing Mode.....	05
Eighth: Operation.....	05
Ninth: Density Setting.....	07
Tenth: Density Reference Table.....	08
Eleventh: Printer.....	09
Twelfth: Unit Choose.....	09
Thirteenth: Packing List.....	09

LIQUID DENSITY SELECT:

SLD	NAME	DENSITY
01	Water (25℃)	0.997048
02	Water (4℃)	1.0000
03	ALCHOL	0.78
04	Kerosene	0.82
05	Hg	13.60
06	Custom	
07	Custom	
08	Custom	
09	Custom	
10	Custom	

Eleventh: Printer

Please use special print to connect with the density balance

When finish density test, there will show the test result on the display, then Press "SET" to print the result after finish the testing.

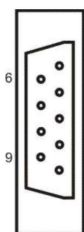

Pin3 - TxD
Pin5 - GND

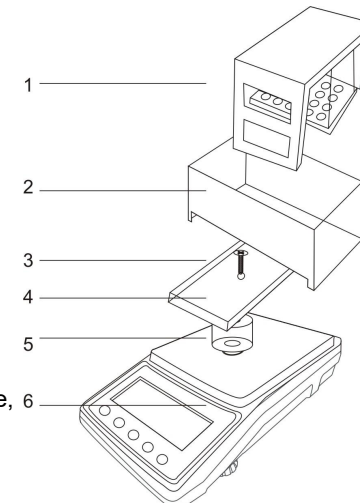

Twelfth: Unit choose

There are 3 units on weighing mode can be choose, 6 press "MENU" can choose the units: g/oz/ct.

Thirteenth: Packing list

Balance---1 set Instruction---1 Pan---1 Power adopter---1
Standard weight---1 The warranty card, certificate---1 Density apparatus---1

Custom density setting : 1) Choose the S-Sd-6 to 10 ,then press enter to confirm the item, then press "MENU" to adjust the setting, Press"SET"add the result,press"ENTER"reduce the result, press "CAL" confirm and go next digit adjust.

Press"ENTER" after all digit set,and then press"CAL"go back..

2.Liquid Density Setting

On density mode, Press "SET" choose the mode to: SLd ,according the item ,means the solid density choose.

*Press"ENTER",it will show: S-Ld-XX,press"ENTER"to enter the solid ,,XX ,01-10,

Means 10 kind of solid density;(6-10 are custom setting)

*Press"ENTER",to choose the density you need,the testing will base on it.

Custom density setting : 1) Choose the S-Ld-6 to 10 ,then press enter to confirm the item, then press "MENU" to adjust the setting, Press"SET"add the result,press"ENTER"reduce the result, press "CAL" confirm and go next digit adjust.

Press"ENTER" after all digit set,and then press"CAL"go back.

Tenth: Density Reference Table

SOLID DENSITY SELECT:

SSD	NAME	DENSITY
01	Wax	0.9
02	Aluminum	2.7
03	Stainless steel	7.8597
04	Silver	10.5
05	Gold	19.3
06	Custom	
07	Custom	
08	Custom	
09	Custom	
10	Custom	

Density balance use high precision weighing sensor and testing device, Its have units convention storage and calculating function.The detection instrument is widely used in scientific research institutions and enterprises

First: Model specification and index

MODE	CAPACITY	READABILITY	PANSIZE
DW203M	210g	0.001g	160x70mm

Second:Working Condition

Working Temperature: 0°~50°C,

Maximum Consumed Power: 5W

Temperature Fluctuation: 5°C/h,

Power Supply: 220V±10% , 50HZ/60HZ

Comparative Humidity: 50% ~85%

Third: Operation Requirements

- 1.Power on and adjust the level in the center;
- 2.Warm up the balance more than 30 minutes;
- 3.Use the standard weight to check the balance,if need calibration please seven point;
- 4.If the balance can't work,please contact us as soon,and please do not dismantled by yourself.
- 5.Please read the manual before use,please do not put on the weight beyond the capacity.

Fourth:Calibration

(1) Calibration Requirements

When distinct error appeared in the weighing of balance, the balance shall be calibrated to make weighing accurate. Calibrated balance shall be placed on the stable working platform without the influences from the vibration of air current and strong electromagnetic wave. The calibration results will be more accurate after turn on and warm up for more than 20 minutes .

(2) Calibration Procedure

Turn on the balance it shall display the weighing mode as "0.000", then press the "CAL" go to the weighing mode, then press "CAL" button until shows "CAL", then release. Display blinkingly the standard weight value and then place same value standard weight; The "===== " will be displayed; then display stably weight value and remove weight. then "===== " will be displayed. the "0.000" will be displayed. The calibration is finished.

(3) Three point calibration

Turn off the balance, then press the "CAL" button and turn on the balance simultaneously until the display shows "CAL", then release. The calibration procedure shall be undertaken as blow:

Display blinkingly the "200.000" then place the same value weight;

Display stably weight value and then remove weight. The "===== " will be displayed;

Display blinkingly the "100.000" and then place the same value weight;

Display stably weight value and then remove weight. The "===== " will be displayed;

Display blinkingly the "50.000" and then place the same value weight;

Display stably weight value and then remove weight. The "0.000" will be displayed;

*then it display: **PODR-2**, when it show powder weight, put on the density bottle filling full with the water, when it goes stable,

Press "ENTER" when it show: **Liquid-3**, take away the density bottle and powder, put the powder inside the bottle, keep the water level same as before (full situation), and put the bottle on the pan, when the weighing value goes stable, then press "ENTER" Then will show: **Liquid-4** the powder density, the density unit is: D means g/cm³;

Press "CAL", and it will go back step one.

***Under the testing state, press "CAL", go back to step one.**

5. ABSORBENT DENSITY TESTING

**Setting the liquid density for test the absorbent things, please check the No IX item.*

*When it display **ABSO**, press "ENTER";

*Then it will display **ABSO-1**, when it show 0.000g, put on the sample on the pan, when it goes stable, Press "ENTER", and not move away the sample;

*then it display: **ABSO-2**, put on the absorbent thing into the water, when it goes stable,

Press "ENTER" when it show: **ABSO-3**, take the absorbent things with water but keep it no drop down the water again, then put it on the pan, when the weighing value goes stable, then press "ENTER" Then will show: **ABSO-4** the absorbent density, the density unit is: D means g/cm³; A and P Press "CAL", and it will go back step one.

***Under the testing state, press "CAL", go back to step one.**

Ninth: Density Setting

*The default liquid density is: 0.998229g/cm³, (20°C water).

1. Solid Density Setting

On density mode, Press "SET" choose the mode to: SSd, according the item, means the solid density choose.

*Press "ENTER", it will show: S-Sd-XX, press "ENTER" to enter the solid, XX, 01-10, Means 10 kind of solid density; (6-10 are custom setting)

*Press "ENTER", to choose the density you need, the testing will base on it.

2. GOLD DENSITY TESTING

*When it show **GOLD** ,press“ENTER”for short time;

*Then it show: **GOLD-1**,when it display 0.000g,put the things on the pan,when it goes stable,then press“ENTER”,and take away the things;

*Then the balance will show:**GOLD-2**,when it display:0.000g,put the things inside the liquid,when the weighing goes stable,then press“ENTER”;

*Then the balance will show **GOLD-3**,and display the k value ;press“ \odot ”you can see the % unit.

Press“CAL”,go back to the step one;

3. LIQUID DENSITY TESTING

**Setting the solid density for test the liquid,please check the No IX item.*

*When it display Liquid ,press“ENTER”;

*Then it will display **Liquid-1**,when it show 0.000g,put on the solid which you know the density on the pan,when it goes stable, Press“ENTER”,and move away the solid;

*then it display: **Liquid-2**,when it show 0.000g,put it inside the liquid,when it goes stable, Press“ENTER”when it show: **Liquid-3** ,and it will show the density,the density unit is:D means g/cm³;

Press“CAL”,and it will go back step one.

***Under the testing state,press“CAL”,go back to step one.**

4. POWDER DENSITY TESTING

**Setting the liquid density for test the powder density ,please check the No IX item.Test the powder density need use the density bottle.(this function no need density kit)*

*When it display PODR ,press“ENTER”;

*Then it will display **PODR-1**,when it show 0.000g,put on the powder on the pan,when it goes stable,Press“ENTER”,and not move away the powder;

Fifth: Installation diagram

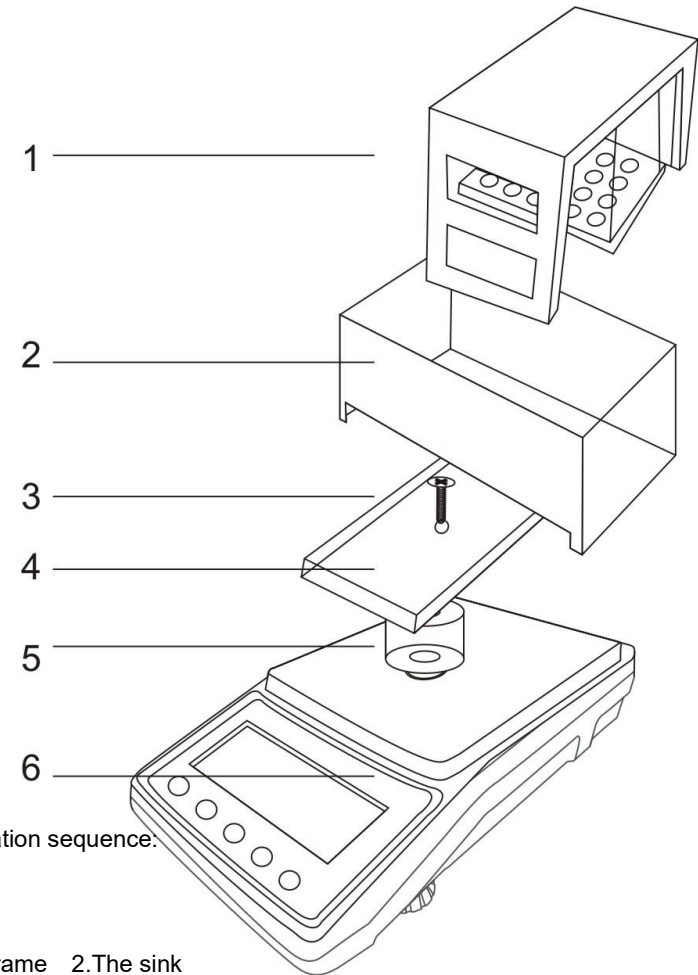

The installation sequence:

1-2-3-4-5-6

- 1.Density frame
- 2.The sink
- 3.Screw
- 4.Tray
- 5.The heighten post
- 6.Density Balance

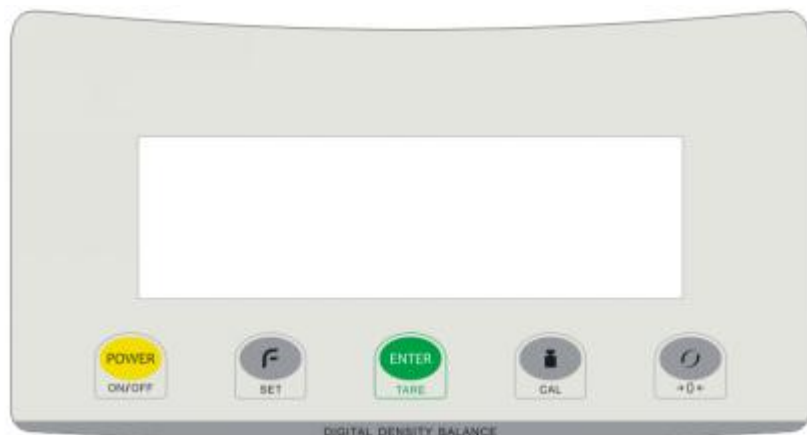

Sixth: Panel And Icon

The key panel / key name / function.

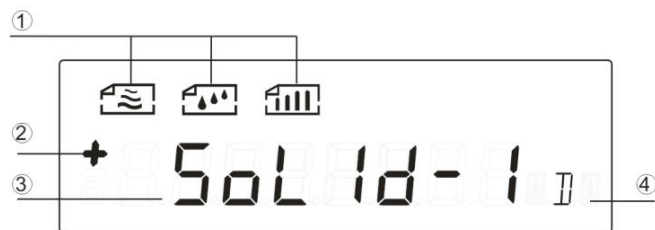

KEY NAME	FUNCTION
ON/OFF	Power on or power off
SET	In density testing situation, use it set or choose the density of liquid or solid sample
ENTER	1. In weighing mode: tare function 2. In density mode: Enter and confirm
CAL	1. In weighing mode: calibration function 2. In density mode: back to weighing mode 3. Set density mode: confirm and go next step
MENU	1. In weighing mode: go to density function 2. In density mode: Tare



1.  Solid and Gold density step icon  Liquid density test step icon
 Powder density test step icon
2. Weighing digit "+" and "-" icon, 3. Test mode and weighing value. 4. Unit icon.

Seventh: Density testing mode

Please check the mode with dealers,
There are five functions density test mode can be choose, but not all function is standard test function.

The unit D means g/cm³.

The default mode is solid density mode.

Press "O" for long time and enter to the density test mode, The display will show:

Press "O" for short time, and choose the Solid, Gold, liquid, Powder (Podr),

Absorbent (ABSO),

Press "ENTER" to enter the density testing.

In this density test mode press "CAL" will back to the weighing state;

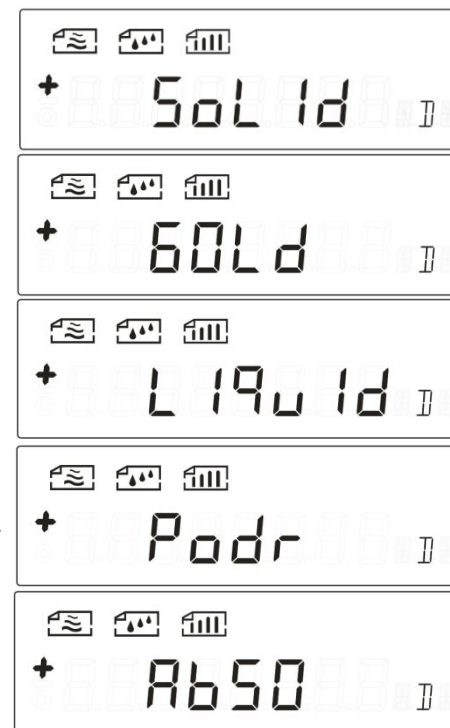

Eighth: Operation

1. SOLID DENSITY TESTING

*When it show Solid ,press "ENTER" for short time;

*Then it show: **Solid-1**, when it display 0.000g, put the things on the pan, when it goes stable, then press "ENTER", and take away the things;

*Then the balance will show: **Solid-2**, when it display: 0.000g, put the things inside the liquid, when the weighing goes stable, then press "ENTER";

*Then the balance will show **Solid-3**, and display the density; press "O" you can see the % unit. Press "CAL", go back to the step one;

Drawell International Technology Limited



Chongqing Drawell Instrument CO.,Ltd

Add: Suite 2705, Building No.12, Shiyou Road No.1, Yuzhong District, Chongqing, China
Tel: 0086-023-63268643

Shanghai Drawell Scientific Instrument Co.,Ltd

Add : Suite 1117, Lane561 XiuChuan Rd., PuDong New Area, Shanghai, China

Web : www.drawell.com.cn

Email : sales05@drawell.com.cn